

Powerex, Inc., 200 Hillis Street, Youngwood, Pennsylvania 15697-1800 (412) 925-7272
Powerex, Europe, S.A. 428 Avenue G. Durand, BP107, 72003 Le Mans, France (43) 41.14.14

Fast Recovery Rectifier
175 Amperes Average
1400 Volts

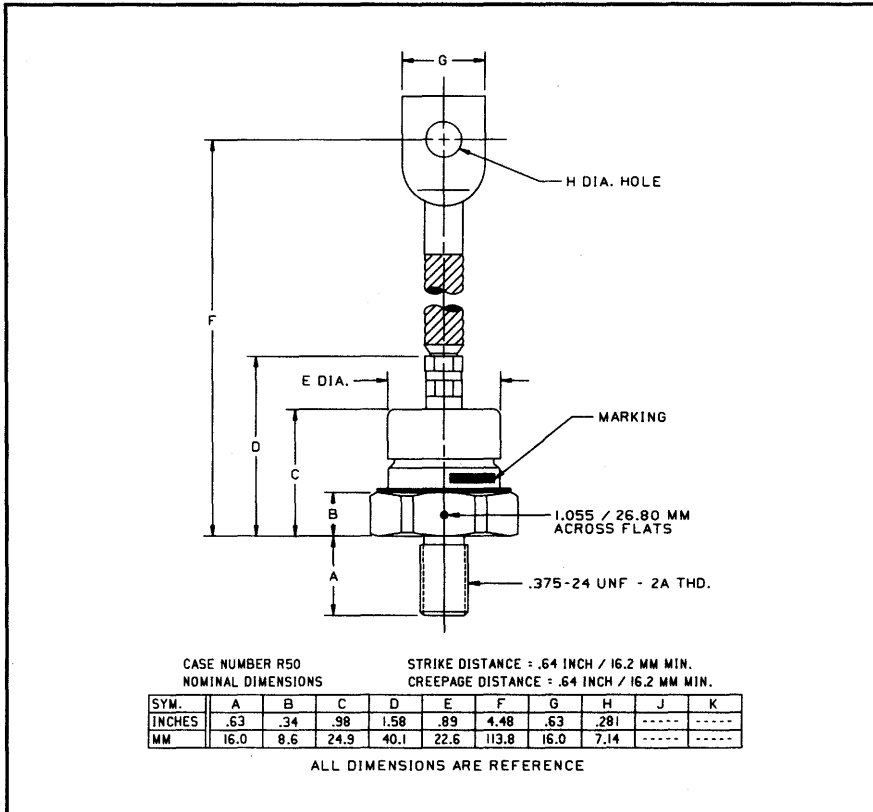

R502__18/R503__18 (Outline Drawing)



R502__18/R503__18
Fast Recovery Rectifier
175 Amperes Average, 1400 Volts

Ordering Information:

Select the complete part number you desire from the following table:

Type	Voltage		Current		Recovery Time		Leads	
	V _{RRM} (Volts)	Code	I _{F(av)} (A)	Code	t _{rr} (μsec)	Code	Case	Code
R502 (Standard Polarity)	200	02	175	18	1.5	FS	DO-8	WA
	400	04						
	600	06						
	800	08						
R503 (Reverse Polarity)	1000	10						
	1200	12						
	1400	14						

Example: Type R502 rated at 175A average with V_{RRM} = 1400V,
Recovery Time = 1.5 μsec and standard flexible lead, order as:

Type	Voltage	Current	Time	Leads
R 5 0 2	1 4	1 8	FS	W A

Features:

- Fast Recovery Times
- Soft Recovery Characteristics
- Standard and Reverse Polarities
- Flag Lead and Stud Top Terminals Available
- High Surge Current Ratings
- High Rated Blocking Voltages
- Special Electrical Selection for Parallel and Series Operation
- Glazed Ceramic Seal Gives High Voltage Creepage and Strike Paths

Applications:

- Inverters
- Choppers
- Transmitters
- Free Wheeling Diode



Powerex, Inc., 200 Hillis Street, Youngwood, Pennsylvania 15697-1800 (412) 925-7272
 Powerex, Europe, S.A. 428 Avenue G. Durand, BP107, 72003 Le Mans, France (43) 41.14.14

R502_18/R503_18
 Fast Recovery Rectifier
 175 Amperes Average, 1400 Volts

Absolute Maximum Ratings

Characteristics	Symbol	R502_18/R503_18	Units
RMS Forward Current	$I_{F(rms)}$	275	Amperes
Average Forward Current	$I_{F(av)}$	175	Amperes
One-half Cycle Surge Current	I_{FSM}	3500	Amperes
I^2t (for Fusing), Times = 8.3 milliseconds	I^2t	51000	A ² sec
Storage Temperature	T_{stg}	-40 to +190	°C
Operating Temperature	T_j	-40 to +150	°C
Mounting Torque (Lubricated)		120	in-lb

Electrical and Thermal Characteristics

Characteristics	Symbol	Test Conditions	R502_18/R503_18	Units
Current - Conducting State Maximums				
Forward Voltage Drop	V_{FM}	$T_j = 25^\circ\text{C}, I_{FM} = 470\text{A}$	1.65	Volts
Voltage - Blocking State Maximums				
Repetitive Peak Reverse Voltage (Rated Limit)	V_{RRM}		1400	Volts
Non-rep. Trans. Peak Rev. Voltage (Rated Limit)	V_{RSM}	$V \leq 5.0\text{msec}$	1600	Volts
Reverse Leakage Current, mA peak	I_{RRM}	T_j at max., $V_{RRM} = \text{Rated}$	45	mA
Switching				
Maximum Reverse Recovery Time	t_{rr}	$I_{FM} = 314\text{A}, t_p = 40\mu\text{sec},$ $di_F/dt = 25\text{A}/\mu\text{sec}, T_C = 25^\circ\text{C}$	1.5	μsec
Thermal				
Maximum Resistance, Junction to Case	$R_{\theta(j-c)}$		0.28	°C/Watt
Maximum Resistance, Case to Sink (Lubricated)	$R_{\theta(c-s)}$		0.12	°C/Watt

R502 - 18/R503 - 18
 Fast Recovery Rectifier
 175 Amperes Average, 1400 Volts

Reverse Recovery Wave Form

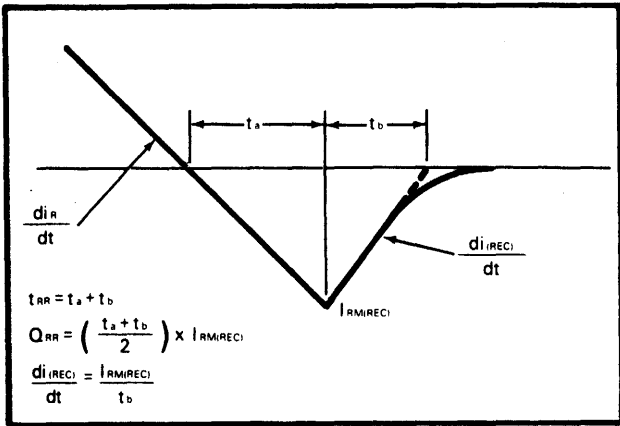

Typical Ratio of Current Recovery to Rate of Current Fall

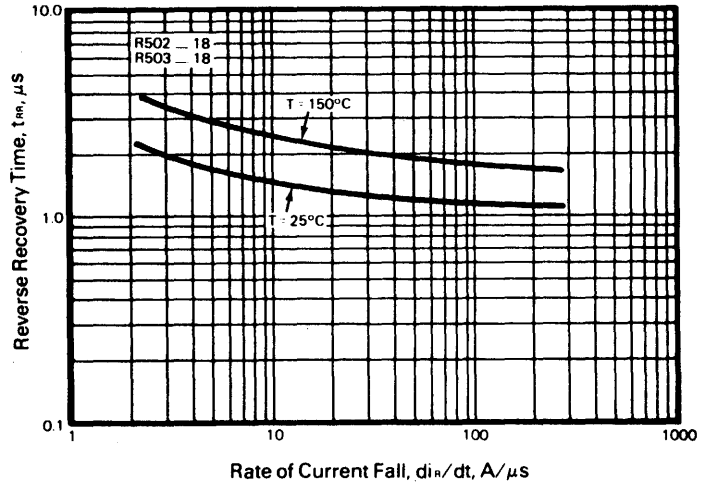

Typical Reverse Recovery Charge Vs. Rate of Current Turn Off

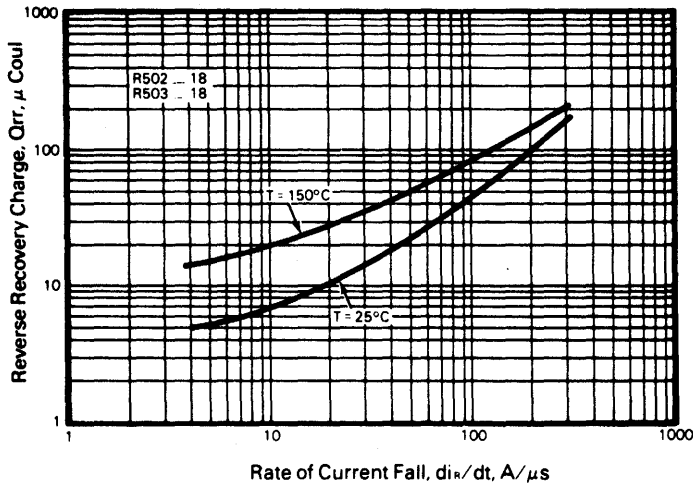

Typical Reverse Recovery Time Vs. Rate of Current Fall

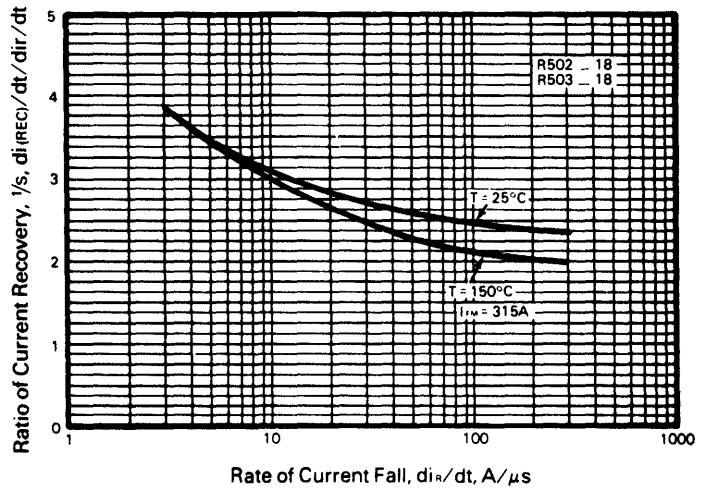

Powerex, Inc., 200 Hillis Street, Youngwood, Pennsylvania 15697-1800 (412) 925-7272
 Powerex, Europe, S.A. 428 Avenue G. Durand, BP107, 72003 Le Mans, France (43) 41.14.14

R502_18/R503_18
Fast Recovery Rectifier
 175 Amperes Average, 1400 Volts

Forward Current Vs. Forward Voltage Drop

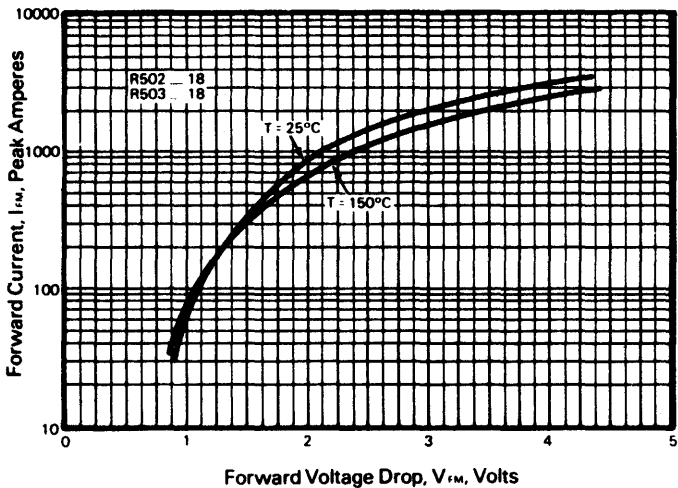

Transient Thermal Impedance Vs. Time

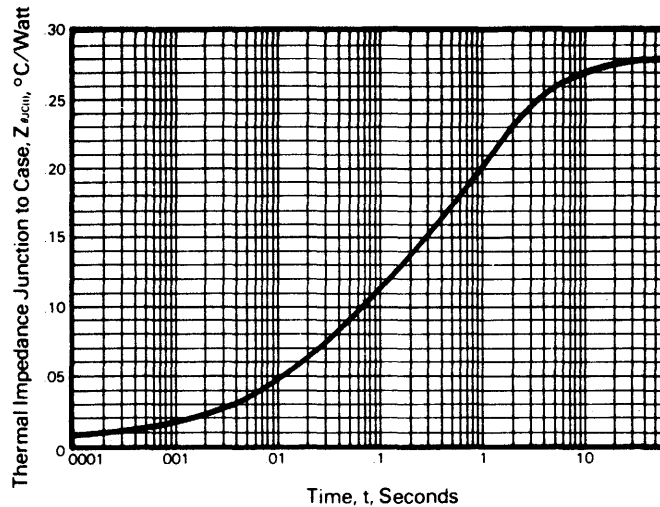

Energy Loss Per Pulse for Sinusoidal Pulses

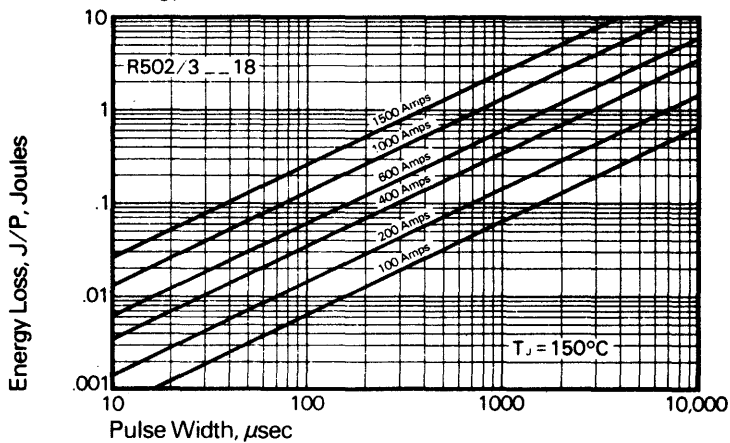

Calculation of Fast Recovery Diodes and Allowable Case Temperature

1. Conduction Losses

$$P_{av(cond)} = J/P \times F$$

2. Reverse Recovery Losses (Approximate)

$$P_{av(sw)} = 1/4 \times V_R \times \frac{di_R}{dt} \times T_{rr}^2 \times \left(\frac{1/s}{1 + 1/s} \right)^2 \times F \times 1 \times 10^{-6}$$

3. Maximum Allowable Case Temperature

$$T_{C(max)} = T_J - (P_{av(cond)} + P_{av(sw)}) \times R_{\theta(j-c)}$$

Where:

$P_{av(cond)}$ = Forward Conduction Power Loss in Watts

$P_{av(sw)}$ = Reverse Recovery Power Loss in Watts

J/P = Energy Loss per Pulse in Joules

F = Frequency in Hertz

V_R = Steady State Reverse Operating Voltage in Volts

di_R/dt = Rate of Decay of Forward Current in Amperes/ μsec

T_{rr} = Reverse Recovery Time in Microseconds

$\frac{1}{1+s}$ = Ratio of Recovery di/dt ($\frac{di_F/dt}{di_R/dt}$)

F = Operating Frequency in Hertz

$T_{C(max)}$ = Maximum Allowable Case Temperature in $^\circ\text{C}$.

T_J = Maximum Operating Junction Temperature in $^\circ\text{C}$.

$R_{\theta(j-c)}$ = DC Junction to Case Thermal Impedance in $^\circ\text{C}/\text{Watt}$.

NOTE - DIM'S ON THIS DWG. ARE FOR REFERENCE ONLY.

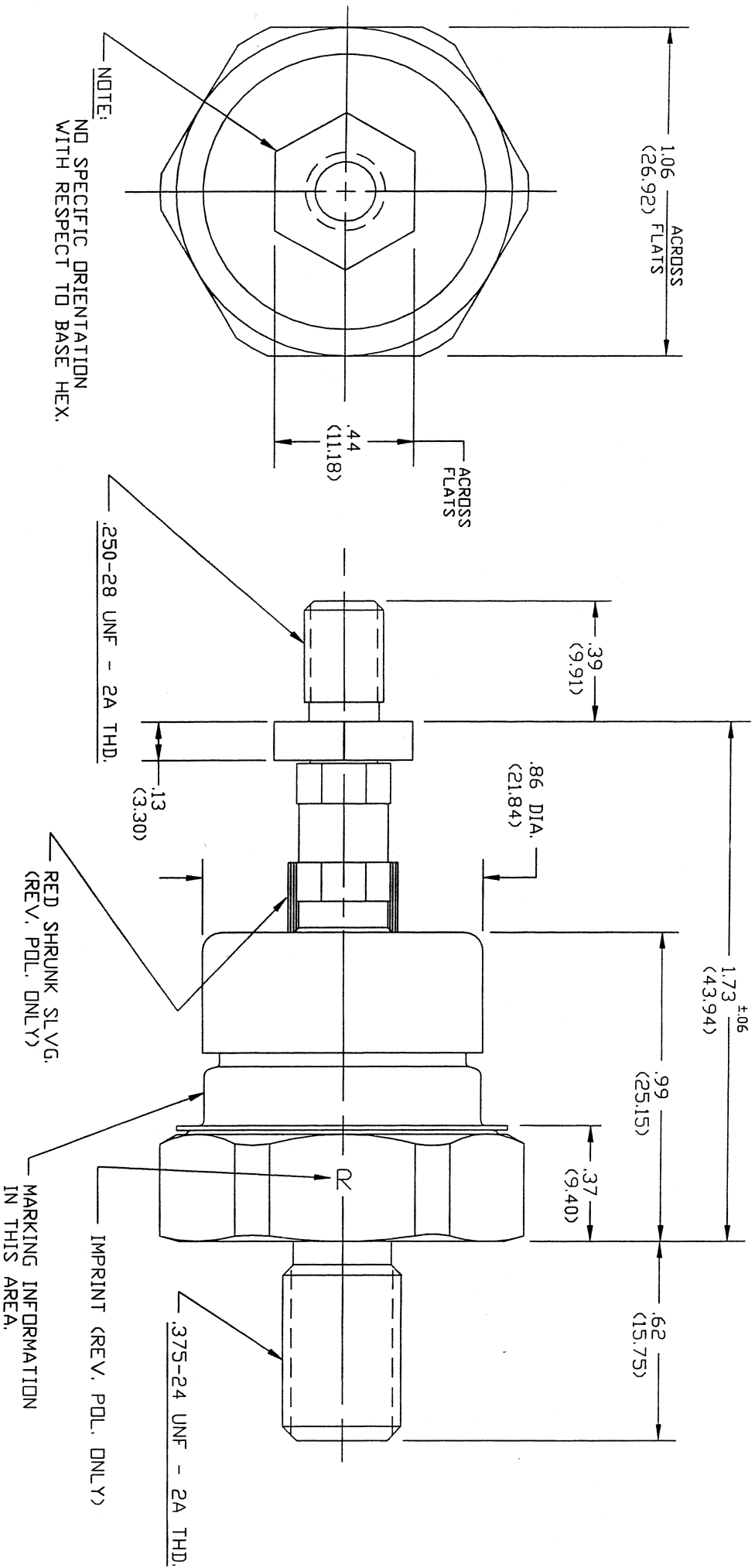

(ALL DIM'S SHOWN IN PARENTHESIS ARE METRIC IN MILLIMETERS.)



Powerex, Inc., 200 Hillis Street, Youngwood, Pennsylvania 15697-1800 (724) 925-7272

Reverse recovery times for
'R' type devices.

TIME, (µsec)	CODE
Std. Rec.	XX
5.0	AS
4.0	BS
3.0	CS
2.5	DS
2.0	ES
1.5	FS
1.25	GS
1.0	HS
0.9	JS
0.8	KS
0.7	LS
0.6	MS
0.5	PS
0.4	QS
0.3	RS